



Liftomatic Material Handling, Inc.

700 Dartmouth Lane
Buffalo Grove, IL 60089

Phone 847 325-2930
Fax 847 325-2959
Toll Free 800 837-6540

LIFTOMATIC OWNERS MANUAL

LIFTOMATIC FORK TRUCK BEAM & LIFTING HOOK

THE LIFTOMATIC FORK-TRUCK BEAM “FTB” SERIES EQUIPMENT

WARNING: Do not install, operate or service this product unless you have read and understand the safety practices, warnings, and operation and service instructions contained in this manual. Failure to follow these guidelines may result in less than efficient drum or material handling routines.

NEVER move any load that is greater than the FTB unit's rated capacity. ***NEVER*** use any FTB or slide-on fork attachment if it will clearly exceed the forklift's true down-rated capacity when using such attachment(s). If you are unsure of the forklift's true down-rated capacity, contact your forklift manufacturer/supplier prior to using the FTB or other slide-on fork mounted products.

Feel free to contact Liftomatic if you require additional information or if you have questions. (PH: 847.325.2930 or FAX: 847.325.2959 or email: sales@liftomatic.com). Thank you very much for your business.

ASSEMBLY / OPERATING / MAINTENANCE INSTRUCTIONS FOR THE LIFTOMATIC “FTB” SERIES (MODEL FTB-1 & FTB-3)

ASSEMBLY:

- 1) Inspect unit upon receipt and ensure no damage has occurred in shipping. The FTB models will arrive completely assembled, but follow the instructions to verify no issues have occurred in transit.
- 2) Remove all protective wrapping, packing materials and container and discard them.
- 3) See that swivel hook assembly (figure #1 on attached parts list) is properly attached to the beam (figure #2). The swivel hook should move freely in a circular pattern when suspended on the forks of the forklift.

****NOTE:** Your area supervisor and or safety department supervisor should verify this product is suitable for use on the forklift chosen to do the lifting. If there are questions in this regard, please consult your supervisor(s) and or the forklift manufacturer for safe load ability and requirements of the forklift. You may also contact Liftomatic at PH: 847.325.2930 or email: sales@liftomatic.com.

OPERATION:

- 1) See that operators are properly dressed with gloves, hard hats, safety glasses and proper footwear.
- 2) Verify that the forklift to be used with the FTB series product is able to handle the load based on the capacity of the vehicle and total weight of the item to be lifted. If questions arise, please contact your area supervisor(s) prior to product use.
- 3) Verify that the load to be lifted does not exceed the capacity of the FTB series unit. Maximum capacity of the FTB-1 is 1000 pounds. Maximum capacity of the FTB-3 is 3000 pounds.
- 4) Slide the FTB series product on the forks of the forklift (the hook should hang below the forks), and attach the FTB's safety chain to the mast of the vehicle.
- 5) The FTB unit should be centered on the forks, or moved closer toward the mast of the truck based on how large the item to be lifted happens to be. The FTB's safety chain should be fastened to the mast of the vehicle. Slack should be removed from the chain by slipping the chain link through the provided key-slot on the FTB unit. After the chain is properly attached and arranged, the FTB unit should be located no further than at the center-point of the forks. Where possible, use the FTB closer to the mast of the truck – this will help to reduce the load center of the load to be lifted.

- 6) Ensure that all travel areas are free from obstruction(s) and debris.
- 7) Attach the FTB's swivel/safety hook to the sling, or other below hook lifting device (such as Liftomatic's BHDL or HCB attachments). Once the lifting product or sling is connected to the FTB, verify again that the FTB unit has located correctly on the forks before use. When the FTB is verified to locate on the forklift forks in the proper location, lift the item slowly until the load is just 1-2 inches off the ground. Verify again that the FTB does remain in the correct place on the forks, and the load does not appear to affect the capacity of the forklift. Forks should be slightly tilted back to eliminate potential for load shift.
- 8) With the load no more than six inches off the ground, safely travel the load to its final destination. The operator should use caution when starting and stopping to eliminate chances for load shift. If the load does shift, SLOWLY stop the forklift, tilt the forks back further, and restart the load transportation. If required, set the load down on the ground, and restart the lifting steps as outlined above.

****NEVER** move any load that is greater than the FTB unit's rated capacity.

****NEVER** use any FTB or slip on fork attachment if it will clearly exceed the forklift's true down-rated capacity when using such attachment(s). If you are unsure of the forklift's true down-rated capacity, contact your forklift manufacturer/supplier prior to using the FTB or other slide-on fork mounted products.

MAINTENANCE:

Check each FTB unit prior to each usage for any excess wear, broken or missing parts. Visually inspect the swivel hook, safety latch on swivel hook and shackle components to which the swivel hook is mounted. Lubricate the swivel hook components weekly (or more often in highly caustic, or dusty/dirty environments). All FTB components should be closely analyzed no less than monthly to ensure all fasteners, safety chain restraint components, and overall unit integrity is not compromised from use and or wear. Replace all components that appear to have compromised integrity immediately with Liftomatic genuine components. It is suggested for all lubrication to use light grade oil. Do not use grease as it can act as a magnet for additional dust/airborne materials. ****NOTE:** After any/all lubrication, verify that the swivel hook moves freely.

If you have any questions specific to the proper use or handling of this product, please consult the manufacturer (Liftomatic) at PH: 847.325.2930 or email: sales@liftomatic.com

Part List for Liftomatic FTB-1

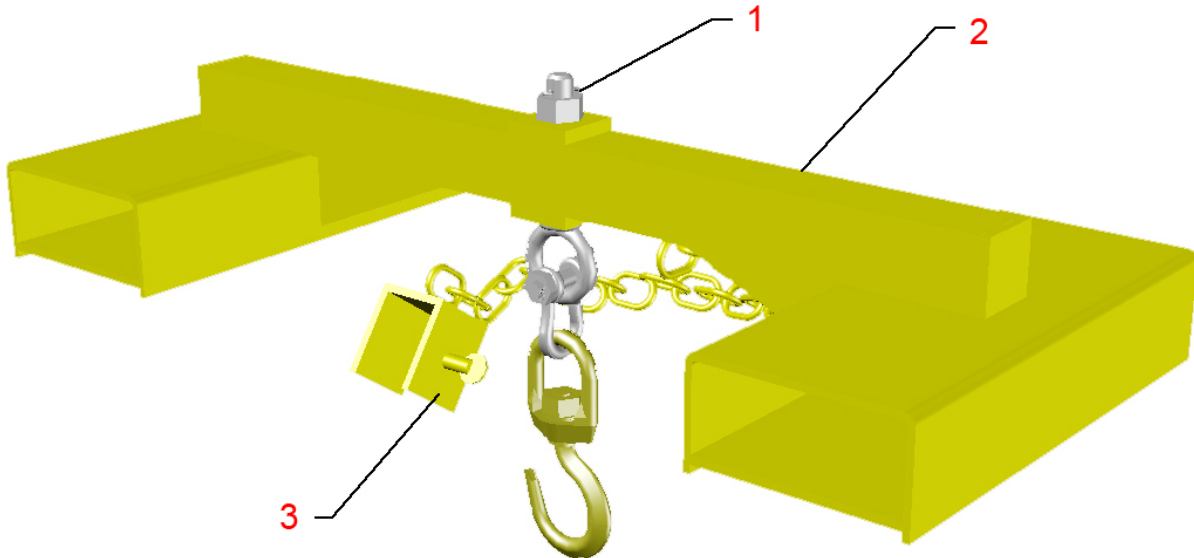

Item	Part Number	Qty	Description
1	4057-1	1	Hook & Linkage Assembly
2	2172	1	Fork Truck Beam
3	4045	1	Safety Chain

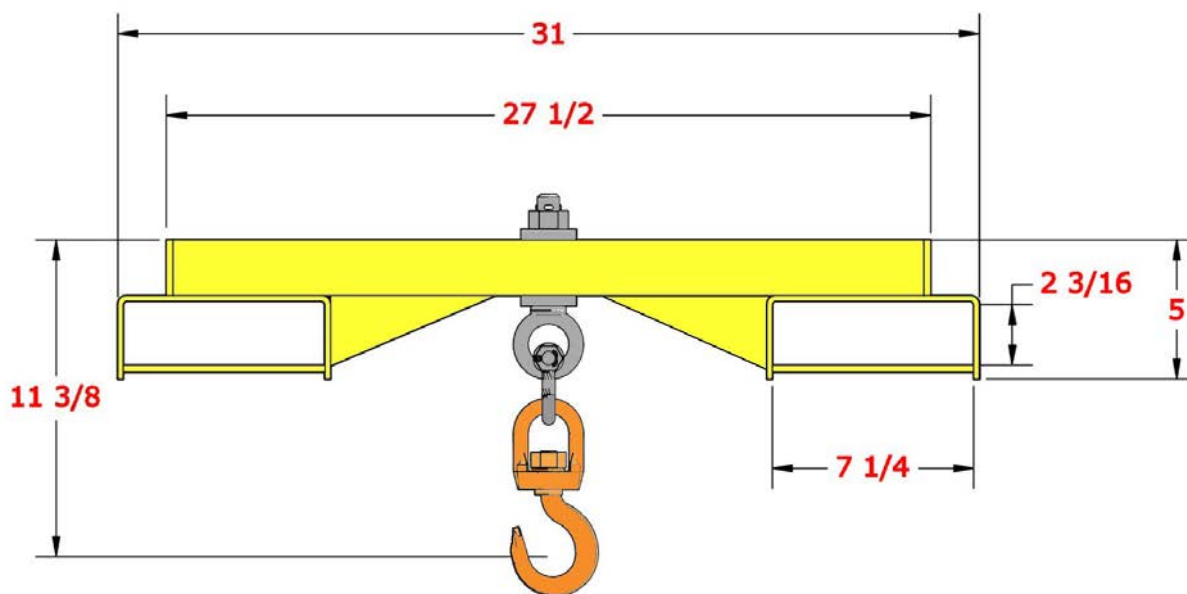

FTB-1

Liftomatic Fork Mounted Hook attachment with Safety Chain